

AFFORDABLE SPACE MIRACLE, MORE ELEGANT THAN EVER BEFORE!

THE ERA OF ECO TOUCH IS HERE! The new JUICI CT 3 ECO model with 10" touch display and very small technology box dimensions combines the advantages of the JUICI CT and the new "JUICI A" software to offer an optimum vending experience!

- 3 drinks + chilled water
- Bag-in-Box concentrates are stored in existing furniture/ base units (larger bags, e.g. 10 litres, are also possible)
- Multilingual flexible touchscreen display with the possibility to show images, videos and advertising on screen for direct communication with your customers
- 1 central drink exit with LED lighting
- Automatic cleaning and increased hygiene through airtight seal of concentrates
- Fully electronic control of concentrate dosage and output quantities
- Remote control (access to statistics, direct error messages and much more)
- Reliable and durable - high-quality materials, robust surface
- Customised design (logo engraved on the column)
- Perfect mixing result through patented MidMix®-system
- Preparation for accounting - OPTIONAL



Individual design possible



Dynamic touchscreen

Central dispensing unit with LED

Standard delivery content

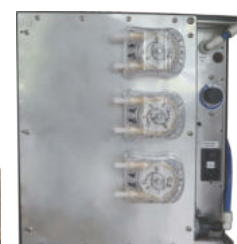

Available in the following versions:

JUICI CT 3 ECO Still

TYPE	JUICI CT 3 ECO STILL
PRICE in € excl. VAT	
Art. No.	frucB0361
Width in mm	242 mm
Height in mm	400 mm
Depth in mm	220 mm
Exit height	215 mm
Weight	8 kg
Pre-selections	OPTIONAL
Product selection buttons (incl. water)	flexibel (touchscreen)
Automatic carafe pre-selection (Extra)	✓
Flavours	3
Mixing ratio concentrates	1+4 ... 1+49
Concentrates in machine	-
Dosage of product selection	150-500ml / PULS
Technics box	3 Pumps Still
Width in mm	310 mm
Height in mm	360 mm
Depth in mm	310 mm
Weight	max.20 kg
Distance technics box/ dispensing unit vertical	max. 1,5 m
Distance technics box/ dispensing unit horizontal	max. 5,0 m
Distance concentrate/ technics box vertical	max. 1,5 m
Distance concentrate/ technics box horizontal	max. 5,0 m
Cooling capacity	28 l/h
Dispensing temperature	extern
Water pressure in bar	min 1,5 bar/max 6 bar
Voltage	230 V/ 50 Hz
Power max.	350 W
with CO2-carbonator	-
FSS ¹⁾	✓
Flowmeter (water)	✓
TFT-Touchdisplay	✓
Dispensing area LED light	✓
Coin validator/cashless	-
Bookkeeping	OPTIONAL
Payment systems	-
Syrup Injection Valve (SIV ²⁾)	✓
Concentrate-empty message	OPTIONAL
Water gallon + pumpset	OPTIONAL
Control of disinfection and sanitation intervals	✓

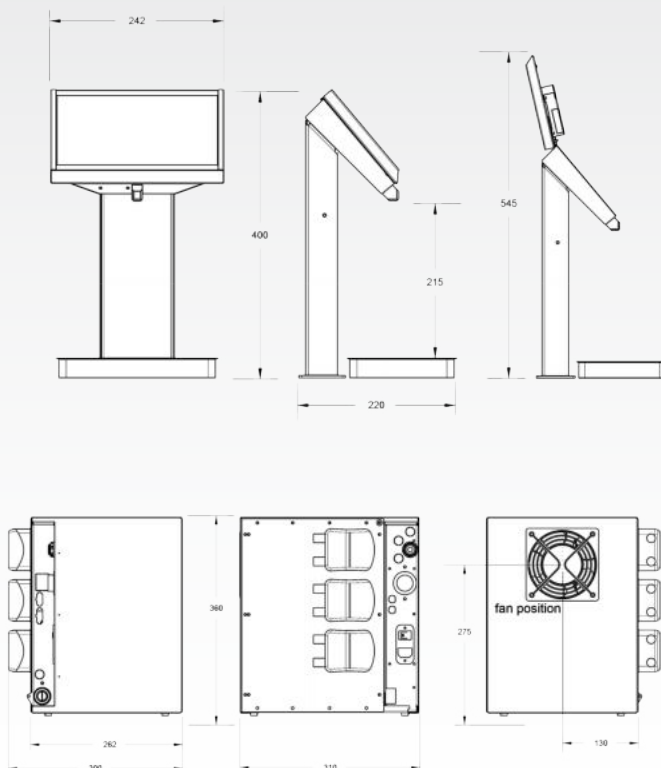

All our models are equipped with the unique and patented mixing system MidMix III.

- 1) FSS = Flood security system: avoids water flood problems due to extra safety valve on water entrance.
- 2) SIV - syrup injection valve for perfect mixing result

SIZE INCL. PACKAGING	JUICI CT LS 3 ECO STILL
Width	570 mm
Height	590 mm
Depth	310 mm
Weight incl. Packaging	37 kg
MACHINE PACKAGE/PALLET	
Europallet 80 x 120 cm	8
UK-size pallet 100 x 120 cm	12



Save resources



Save on warehousing and transport



Save energy



Reduce CO2 emissions



MADE IN AUSTRIA

FRUCTOMAT

BY ASCO DRINK MACHINES